

Maxseal Solenoid Operated Valves



ICO4S
1/4" 3/2
PBMR



Typical Applications

- 1/4" 3/2 PUSH BUTTON MANUAL RESET
- Actuator Control
- Direct Acting Shut Off Valve
- Oil & Gas Applications
- Turbine Fuel Control

Thompson Valves Ltd

Description

- Model: ICO4S 1/4" 3/2 Uni Direct Acting Solenoid Valve
- Low Pressure, High Flow
- Max Inlet Pressure 20 bar (290 psi)
- Reliable and long life, ideal for a one time installation
- Control of pneumatic or hydraulic operated equipment

<input type="checkbox"/> Standard Features	<input type="checkbox"/> ICO4S 1/4" 3/2 PBMR
<input type="checkbox"/> Solenoid Materials of Construction	<input type="checkbox"/> Solenoid Pot - Stainless Steel - BFC 316 <input type="checkbox"/> Top Cover - Stainless Steel- BFC 316 <input type="checkbox"/> Valve Body & Trim Materials - 316 Stainless Steel <input type="checkbox"/> O-Rings Seats & Seals - High Nitrile (NBR) <input type="checkbox"/> Coil Insulation - Class H
<input type="checkbox"/> Maximum Inlet Pressure	<input type="checkbox"/> 20 Bar (290 PSI)
<input type="checkbox"/> Flow Rates	<input type="checkbox"/> $C_v = 0.8$ USgpm for 1 psi Δp <input type="checkbox"/> $K_v = 11.5$ l/min for 1 bar Δp
<input type="checkbox"/> Temperature Ratings	<input type="checkbox"/> Media (Min/Max -20°C/90°C) - Ambient (Min/Max 0°C/60°C)
<input type="checkbox"/> Valve Size	<input type="checkbox"/> 1/4" Balanced Poppet Valve
<input type="checkbox"/> Process Connections	<input type="checkbox"/> 1/4" NPT
<input type="checkbox"/> Conduit Connection	<input type="checkbox"/> M20 x 1.5 Conduit Thread
<input type="checkbox"/> Media	<input type="checkbox"/> Liquid & Gases
<input type="checkbox"/> Weight	<input type="checkbox"/> 5.5 Kg

<input type="checkbox"/> Recommended Spares Kits		
<input type="checkbox"/> Soft Spares (O-rings, Springs etc)	<input type="checkbox"/> Standard & Extreme Service <input type="checkbox"/> Low Temperature valves	Y123A010000-SS See Valve Data Sheet
<input type="checkbox"/> Spare Coil Assembly	<input type="checkbox"/> Standard 24V DC (4.5 Watts) <input type="checkbox"/> Other Variations	Y123A0101B0 See Valve Data Sheet

<input type="checkbox"/> Options	
<input type="checkbox"/> Valve Body & Trim Materials	<input type="checkbox"/> Aluminium Bronze - Sea Water Applications <input type="checkbox"/> Titanium - Extreme Service Applications
<input type="checkbox"/> Low Temperature Options	<input type="checkbox"/> O-Rings - Low Nitrile / Fluorosilicone (Min Med/Amb -40°C/-40°C)
<input type="checkbox"/> High Temperature Options	<input type="checkbox"/> High Temperature Spacer (Max Med/Amb 120°C/60°C) Please Call for Dimensions
<input type="checkbox"/> Process Connections	<input type="checkbox"/> Thread - 1/4" BSPP
<input type="checkbox"/> Conduit Connection	<input type="checkbox"/> 1/2" NPT
<input type="checkbox"/> Extreme Service	<input type="checkbox"/> Increased Power Consumption
<input type="checkbox"/> Product lead time	<input type="checkbox"/> Y123PA1H1BS - 1 WEEK (SUBJECT TO QUANTITIES) <input type="checkbox"/> Other Variations - Please call for possible delivery dates

Technical Specification

Pressures	
Test (Proof) Pressure	<input type="checkbox"/> 30 bar (435 PSI)
Maximum Inlet Pressure	<input type="checkbox"/> 20 Bar (290 PSI)
Maximum inlet pressure when used in 'Universal Operation'	<input type="checkbox"/> 15 bar (218 PSI)
ATEX Classification	<input type="checkbox"/> Complies with ATEX Directive 94/9/EC
ATEX Certificate	<input type="checkbox"/> SIRA 00ATEX1147
Certification	<input type="checkbox"/> II 2G
	<input type="checkbox"/> EExd IIC T6 (T _a = -60°C to + 48°C) or
	<input type="checkbox"/> EExd IIC T4 (T _a = -60°C to + 90°C)
	<input type="checkbox"/> IECEx
IECEX	<input type="checkbox"/> IECEx BAS 04.0019
	<input type="checkbox"/> EExd IIC T6 (T _a = -40°C to + 60°C) or
	<input type="checkbox"/> EExd IIC T4 (T _a = -40°C to + 90°C)
GOST 'K'	<input type="checkbox"/> EExd IIC T6 (T _a = -40°C to + 60°C)
GOST 'R'	<input type="checkbox"/> EExd IIC T6 (T _a = -40°C to + 60°C)
Safety Integrity Level	<input type="checkbox"/> Suitable for SIL 3 Application in Simplex Mode
	<input type="checkbox"/> Suitable for SIL 4 Application in Duplex Mode
Ingress Protection	<input type="checkbox"/> IP66/X8, NEMA 4X
Voltage Surge Protection	<input type="checkbox"/> Surge Suppression Diodes
Coil Insulation	<input type="checkbox"/> Class H
Performance	
Pull-in Voltage	<input type="checkbox"/> 87.5% of Nominal
Response Times	<input type="checkbox"/> Pull-In <150ms
	<input type="checkbox"/> Drop-Out <80ms
Electromagnetic Compability (EMC)	<input type="checkbox"/> EN50081-2/82-1

Valve Symbol

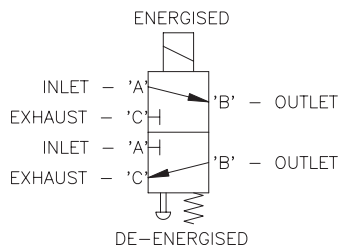

VALVE SYMBOL FOR
ENERGISE TO OPEN
(DE-ENERGISED TO CLOSE)
(NORMALLY CLOSED)
20 BAR MAX WORKING PRESSURE
STANDARD OPERATION

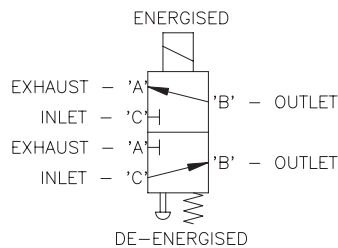

VALVE SYMBOL FOR
ENERGISE TO CLOSE
(DE-ENERGISED TO OPEN)
(NORMALLY OPEN)
15 BAR MAX WORKING PRESSURE
UNIVERSAL OPERATION

Extreme Service valves can be offered with 20 Bar (290 psi) for use in the Universal Operation

Ordering Information

Model	Operating Pressure	Port Config.	Operation	Process Connection	Seat/Seal Materials	Conduit Connection	Voltage	Body/Trim Materials
Y1	2	3	P	A1	H	1	B	S
ICO4S	0-20 Barg (290 psi)	3/2 UNIVERSAL	PUSH BUTTON MANUAL RESET	A1	H High Nitrile	1	A 18/33V DC	S 316 SS / 316 SS
				1/4" NPT			B 24V DC	
				E1	V Viton®	2	C 50V DC	M Alu Brnz / Alu Brnz
				1/4" BSPP			J 110V AC	
					1/2" NPT	M 240V AC	3 Titanium / Titanium	
						R 115V DC		

Ordering Example

Y1	2	3	P	A1	V	2	A	S
ICO4S	0-20 Barg (290 psi)	3/2 UNI	PBMR	1/4" NPT	VITON®	1/2" NPT	18/33V DC	316 SS / 316 SS

Power Consumption (At Nominal)

DC Standard		AC Standard		Extreme Service	
18 / 33V DC (24V DC)	7.7 W	25V AC	6.5 W	24V DC	9.6 W
24V DC	4.5 W	110V AC	6.5 W	Others Available	
50V DC	5.5 W	240V AC	6.2 W		
115V DC (110V DC)	8.0 W				
115V DC (125V DC)	10.4 W				

Profile and Dimensions mm

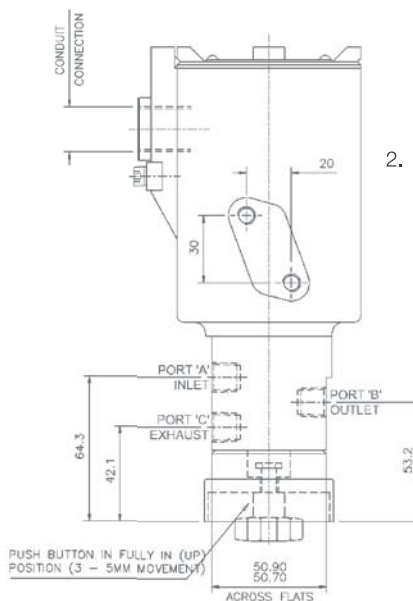
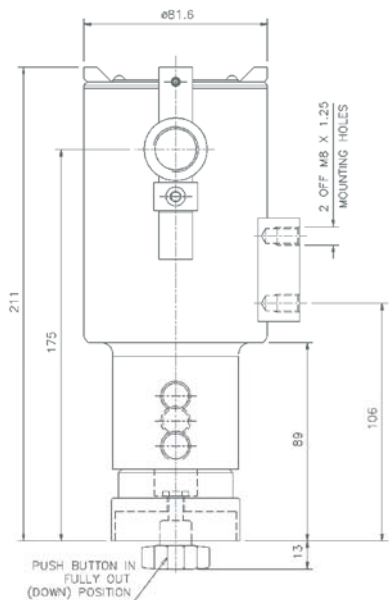

1. Valve is energised
Valve does not move.
Flow occurs between ports 'B' & 'C'

Push button is pushed upwards
Valve 'changes over'
Flow occurs between ports 'A' & 'B'

2. Valve is de-energised
Valve resets
Flow occurs between ports 'B' & 'C'

Push button is pushed upwards
Valve does not move.
Flow occurs between ports 'B' & 'C'

Thompson Valves reserves the right to amend product specifications or designs without notice. Information is given in good faith and no liability can be accepted for error or omission. Viton® is a registered trademark of DuPont Performance Elastomers.

Thompson Valves, 17 Balena Close, Creekmoor, Poole, Dorset BH17 7EF, ENGLAND
Tel +44 (0)1202 647331 Fax +44 (0)1202 647302 Email maxseal@thompson-valves.com
www.thompson-valves.com A fluid controls business of IMI plc